

Total No. of Printed Pages:3

SUBJECT CODE NO:- E – 06
FACULTY OF ENGINEERING AND TECHNOLOGY
T.E.(MECH/PROD) Examination Nov/Dec 2017
Desing of Machine Elements - II
(REVISED)

[Time: Three Hours]

[Max.Marks:80]

Please check whether you have got the right question paper.

- N.B
1. Attempt any three questions from each section.
 2. Assume suitable data if necessary.
 3. Use of non-programmable calculator & design data book is allowed.
- Section – A
- Q.1 A pair of spur gears with 20° full depth involute teeth consists of 25 teeth Pinion Meshing with 75 teeth gear. The Pinion rotates at 1760 r.p.m. & receives 30 KW power through its shaft. The Pinion as well as gear are made of steel & the permissible bending stress is 150 MPa. The gears and machined to the accuracy of Grade – 10 for this grade $e = 16 + 1.25\phi_p$. Where $\phi_p = M + 0.25\sqrt{d}$ where e is the error in microns and m & d are module & pitch circle diameters in mm, respectively design the gears. Specify their dimension & find out – the required value of surface hardness for the gears. 14
- Q.2 Two parallel shafts are connected by a pair of helical gears to transmit 15 kw at 4000 r. p. m. of pinion. The safe static strength for the material of both gears is 100 MPa. Gear ratio is 4 stub teeth with 20° pressure angle in diametral plane have helix angle of 45° . Calculate the necessary BHN from the wear consideration check the design for beam strength and dynamic load. 13
- Q.3 A pair of bevel gears with 20° pressure angle consist of 20 teeth pinion meshing with a 30 teeth gear. The module is 4mm while the face width is 20 mm. The material for the Pinion & gear is steel 50cu (sut = 750 N/mm^2). The gear teeth are lapped & ground (class – 3) & the surface hardness is, 400 BHN. The Pinion rotates at 500 r.p.m. and receives 2.5kw power from the electric Motor. The starting torque of the motor is 150% of the rated torque. Determine the failure of safety against bending failure & against pitting failure. 13
- Q.4 A plate clutch is to transmit 130kw at 400r.p.m. The plate clutch has maximum diameters of 540mm with maximum lining pressure 0.3 MPa. The coefficient of friction is 0.28. Determine inside diameter & spring force to engage the clutch. If safe shear stress for the spring material is 560mpa, the spring index is 7 and six springs are used, determine spring wire diameter. 13
- Q.5 Write short note on (Any three)
- a) Causes of gear failure
 - b) Merits & demerits of worm & worm wheel.
 - c) Types of gear trains
 - d) Friction materials of clutches.

2017

Section – B

- Q.6 a) Explain bearing characteristics number explaining its significance in the design of sliding contact bearing. 04
- b) Following data refers to 360° (full) Hydro dynamic bearing. 10
 Journal diameter = $d = 75\text{mm}$.
 Bearing length = $l = 75\text{mm}$
 Radial clearance = $C = 0.05\text{mm}$.
 Minimum film thickness = $h_o = 0.02\text{mm}$
 Journal speed = $N = 420\text{r.p.m}$
 Radial load = $W = 3500\text{N}$
 C_p for oil = $1.75 \text{ kJ / kg}^\circ\text{C}$
 ρ of oil = 0.9 gm / CC .
 Calculate
 a) Required viscosity of oil z
 b) The coefficient of friction μ
 c) The heat generated H_g
 d) The amount of oil Pumped through the bearing's.
- Q.7 A deep groove ball bearing with the inner race rotation has a 10 sec work cycle as follows 13
 For 2sec : $F_r 3567 \text{ N}$ $f_a = 178\mu\text{N}$,
 $N = 900\text{r.p.m}$ & light shock for 8 sec $F_r = 2675\text{N}$
 $f_a = 0$, $M = 1200 \text{ r.p.m}$. & steady shock .
 The static & dynamic load ratings of the bearing are $C_o = 16225 \text{ N}$ and $C = 22825 \text{ N}$ respectively
 find the rating life of the bearing in years of 275 days each for 8 hrs a day operation.
- Q.8 a) Explain the initial tension in belt . 03
 b) Two pulleys of 100mm & 150mm in diameter are connected with open flat belt. The centre distance is 400mm. 10 kw of power is transmitted with a belt of speed of $0.96 \times 10^6 \text{ mm/min}$. Assume $\mu = 0.3$, a slip of 2% on driver shaft & 1.5% that on the driver shaft, 5% friction loss at each shaft & an overload of 20% determine
 a. r.p.m of each shaft
 b. Belt tension
 c. Length of belt. 10
- Q.9 A differential band brake is shown in figure 01. The width & thickness of the steel band are 100mm 13
 & 3 mm respectively & the maximum tensile stress in the band is 50 N/mm^2 . The coefficient of friction between the friction lining & the brake drum is 0.25 calculate
 i) The tension in the band
 ii) The actuating force
 iii) The torque capacity of the brake.

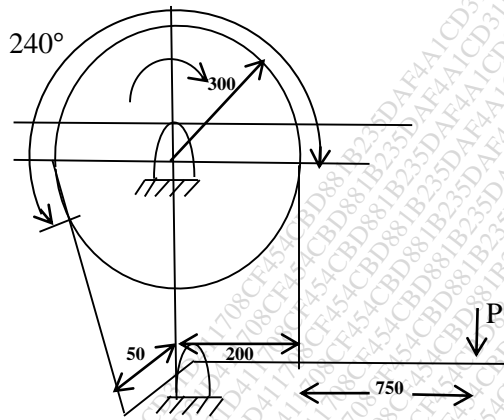

Figure – 01

Q.10 Write short note on (Any three)

- Petroff's equation
- Miner equation
- Stribeck's equation
- Chain drive.