

SUBJECT CODE:- 285
FACULTY OF ENGINEERING AND TECHNOLOGY
F. E.(ALL)Examination Nov/Dec 2015
Engineering Graphics
(Revised)

[Time: Four Hours]

[Max. Marks: 80]

“Please check whether you have got the right question paper.”

N.B i) Solve any three questions from each section.

ii) Assume suitable data if necessary and mention if clearly.

iii) Figures to the right indicate full marks.

Section A

- Q.1 A line CD 80mm long is inclined at an angle of 30° to HP and 45° to VP. The point C is 20mm above HP and 30mm in front of VP. Draw the projections of the straight line. 13
- Q.2 A line AB 90mm long is inclined at 45° to HP and its view makes an angle of 60° with the VP. The end A is in HP and 12mm in front of VP. Draw its front view and find its true inclination with VP. Also locate the traces. 13
- Q.3 A 30° - 60° set square of 90mm longest side is so kept that, the longest side is in HP. Making an angle of 30° to VP and surface of set square is 45° inclined with HP. Draw the projections of set square. 13
- Q.4 A regular pentagonal pyramid with the sides of its base 30mm and height of axis 85mm rests an edge of base on HP. The base is tilted until its apex is 50mm above HP. Draw the projections of pyramid, when the edge on which it rests is parallel to VP and the apex is towards the observer. 14
- Q.5 A square prism of 40mm diagonals and 70mm axis is resting on its base on HP. It is cut by a section plane perpendicular to VP and inclined to HP and bisecting the axis so that the true shape of the section is a rhombus having diagonals 40mm and 60mm long. Obtain the sectional top view and true shape of the section. Also determine the inclination of cutting plane with HP. 13

Section-B

- Q.6 A right circular cone 75mm diameter and 100mm axis length is resting on its base in HP. A point P initially situated at the extreme end of base moves around the surface of the cone and finally comes back to starting point. Find the distance of shortest path; the point P will take in covering the distance along the surface of cone. Also show path in front view and top view. 13
- Q.7 Fig.1 shows isometric view of an object. Draw front view, top view and side view of it. 14

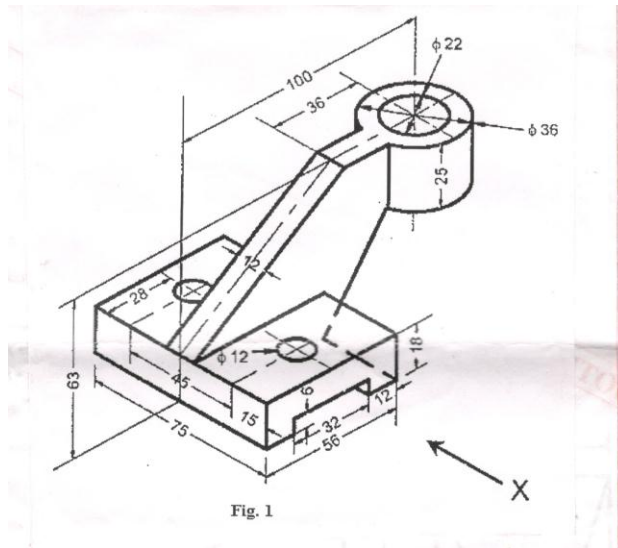

- Q.8 Two views are given in fig.2. draw
1. Sectional side view-section A-A
 2. Top view
 3. Redraw front view

13

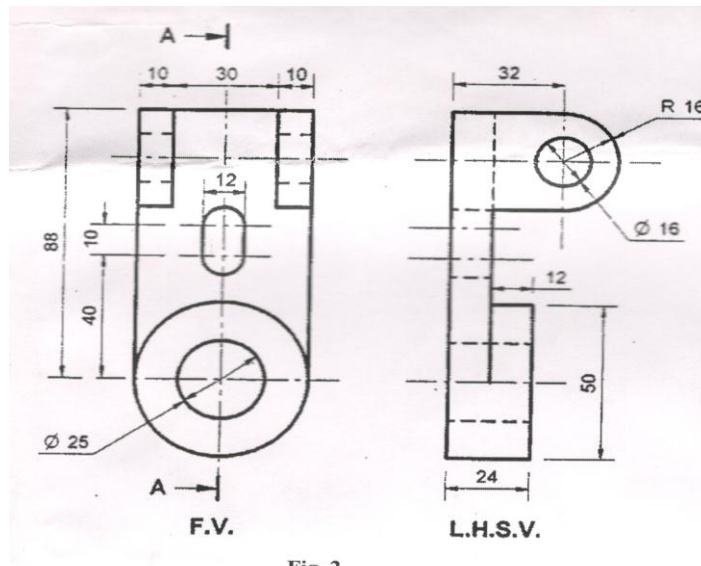
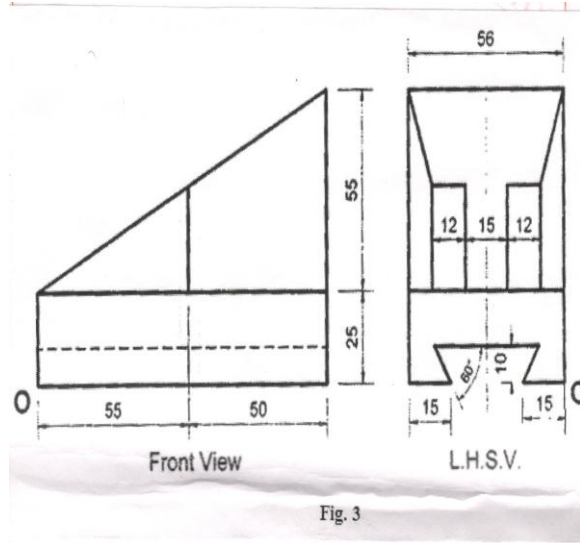

Fig. 2

- Q.9 Two views of an object are given in fig.3. Draw its isometric view.

13



Q.10 Draw freehand sketches of the following (any three)

13

- Acme threads
- Single riveted double strap butt joint
- Rag foundation Bolt
- Gib headed key
- Castle nut.